

SpaceClaim Professional 2007

Modern, Open 3D at Your Fingertips

SpaceClaim Professional 2007 is the 3D productivity tool for engineers who contribute to the design and manufacture of mechanical products across a broad range of industries. The software provides a flexible design environment coupled with a modern user experience that speeds contributions to the product development process. SpaceClaim bridges the gap between designers and those in the extended product development team—such as concept, analysis and manufacturing engineers, engineering management and suppliers, who lack access or time to master the designers' 3D CAD system. SpaceClaim has an open file format and data exchange capabilities to support design sharing and ensure fit within the existing development process.

Advanced Technology

Dynamic Modeling technology provides a highly-adaptive design environment that supports unanticipated design directions, making SpaceClaim ideal for conceptual design, design creation, and modification.



Geometric Inferencing

works unobtrusively and in real time to highlight design similarities, such as equal radius holes or coplanar surfaces, during geometry creation and modification, improving user productivity.

Associations collect related geometry together and apply design intent, such as mirror or pairing of surfaces. Associations can be readily turned on or off as the design needs change.

Integrated Workspace for parts and assemblies supports top-down concept design by enabling creation and freely splitting and merging of components as the design progresses.

Open XML data format makes all design data accessible for product data management and downstream applications, ensuring long-term protection of customer data.

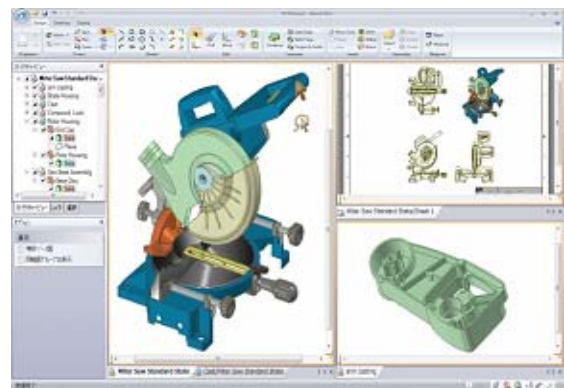
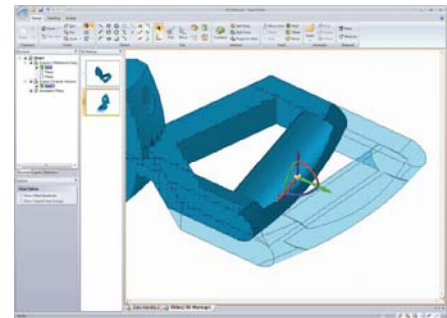

Work in 3D

SpaceClaim makes 3D accessible by enabling users to focus on their design, rather than on how to master the design software. Geometry can be created and freely modified as the design evolves from initial concept without knowing the final detailed design. This unprecedented level of design freedom makes it easy for anyone to work with a model, even one that was created by someone else. Design changes are made by directly selecting the geometry and pulling it to a new location. The design adapts in real time to the change based on what geometry is selected and the operation performed. The result is fast and flexible design changes that improves the quality of each design iteration and enhances personal productivity.

Sketch environment lets users create sketches and try new ideas quickly. Users can sketch to exact dimensions or create a rough layout for future modification. Sketching entities include lines, arcs, and splines. Sketching tools include trim, offset, and project to sketch. Sketches remain free of constraints, making the resulting 3D geometry completely flexible. This approach requires no advanced knowledge of final part design or detailing requirements.

Pull Tool creates and modifies geometry with a simple action. Users can pull a surface to create an extrusion, pocket, or hole. Users can also pull a surface to rotate it around an axis or to create sophisticated geometry by blending through different sections. Pulling a profile along a path creates a sweep, and pulling an edge creates a round or chamfer.

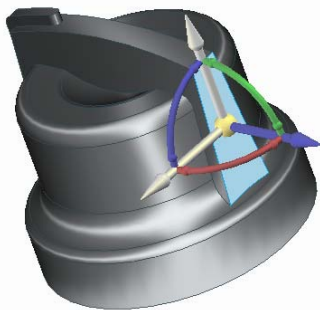
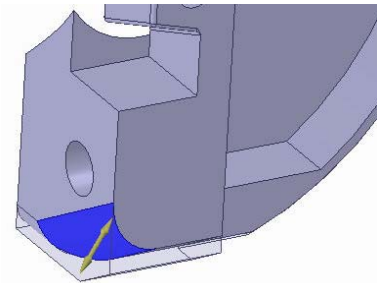

Move Tool speeds the process of moving or copying geometry in a design by providing a 3D handle to reference how geometry should be located along a specified direction or rotated about an anchor point. SpaceClaim also supports familiar Microsoft commands to move and copy geometry.

Section Tool provides a way to modify a 3D model by directly changing section geometry located at any cross section through the design. This intuitive operation is familiar to those used to working in 2D.

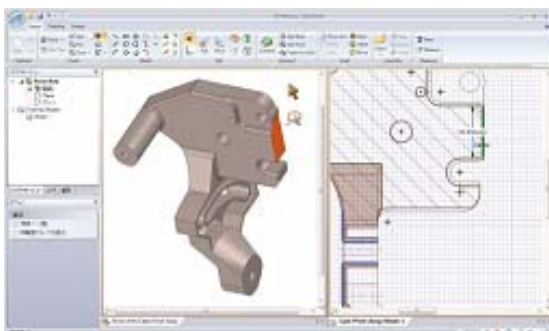
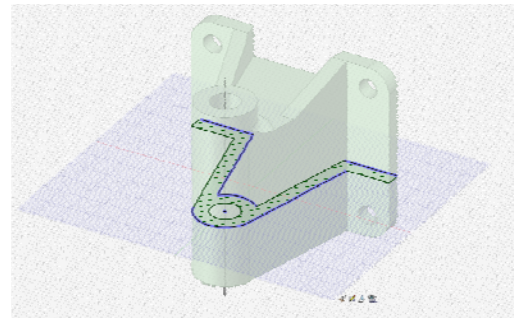

Associative Drawing environment enables design changes, as well as geometry creation and modification, from within drawing views. The drawing environment provides a familiar work space for those accustomed to working in 2D. Drawings support annotations, including geometric dimensioning and tolerances, notes and leaders, to JIS, ISO, and ANSI[®] standards.

Raise Productivity

SpaceClaim takes advantage of modern user interface design and processing power to deliver the highest-level of user productivity. A single command performs multiple tasks based on user selection and context. The advanced GUI based on the latest Microsoft® technology enables users to focus on working with the design, rather than on working with the software. The interface provides all relevant options in a “heads-up display” along side the mouse cursor, eliminating unnecessary and time consuming mouse movements. SpaceClaim learns user preferences by tracking previous selections and actions, presenting them back to the user whenever relevant. The result is a highly efficient design environment and exceptional user experience.

SmartTools™ understand the user’s modeling intent simply by recognizing what geometry is selected and in what context. By determining what operation to perform without excessive drop-down menus, dialogue boxes, and user clicks, SpaceClaim dramatically improves users’ productivity.

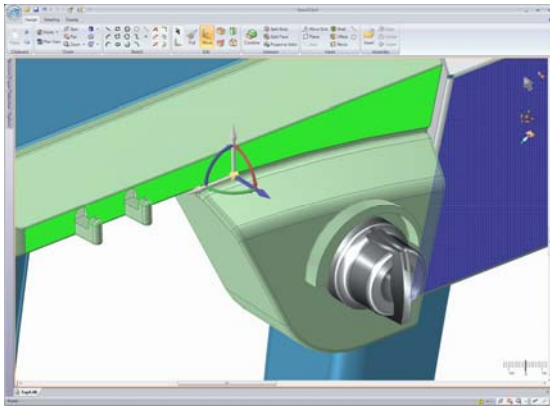
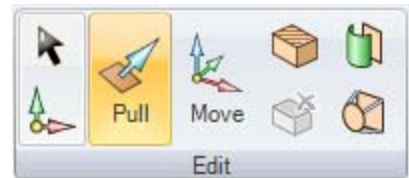

Hints provide helpful, real time feedback to the user as they create or modify geometry. Hints automatically present design considerations, such as maintaining same size holes or wall thickness, in the form of localized “snaps” to similar, surrounding geometry. Hints eliminate the need for the user to enter specific dimensions or interrogate the model before changing or adding geometry.

PowerSelect™ enables users to search the model for like geometry and to easily select subsets or an entire group from the resulting list in order to modify, move, or delete all at once. Additionally, previously selected geometry groups are remembered and presented to the user. Given the frequency with which users perform selection, this streamlined process accelerates user’s modeling productivity.

Tool Guides are tool specific graphical icons that appear after a major tool or operation is selected. The guides present the possible uses of each tool in a clear, graphical format and help the user in completing the selected operation. The selected graphical icon displays along side the cursor to give clear indication of the current task.

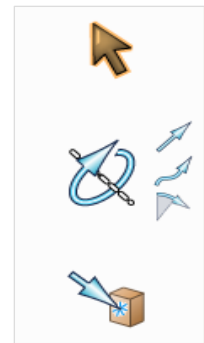

“Heads-up” Display makes use of the latest Microsoft technology, to put relevant commands and choices right where you are working, without getting in the way or requiring you to scroll through drop down menus in search of commands. Fewer mouse movements means more time working with your design.

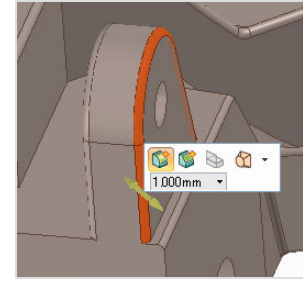

Tool Tips and Animated Help are provided for each operation. Whenever the mouse cursor moves over a command icon, a tool tip appears with a brief description and a link to a more detailed explanation and steps for its use. The detailed descriptions include animations to clearly demonstrate the use of the tool.

Benefit from Industrial-Grade 3D

SpaceClaim Professional 2007 provides a robust modeling environment and includes a powerful set of creation and modification tools for the design of mechanical parts and assemblies. The solution provides an integrated workspace ideal for top down design because as the design evolves components can be easily merged and split into separate parts all in a single workspace.

Integrated Workspace provides a single design environment for working on an assembly and its individual components. The approach is ideal for top-down design because parts can be easily merged together or split into individual piece parts as the design evolves. Additionally, the assembly structure and hierarchy can readily be changed simply by dragging and dropping component designations around in the design tree.

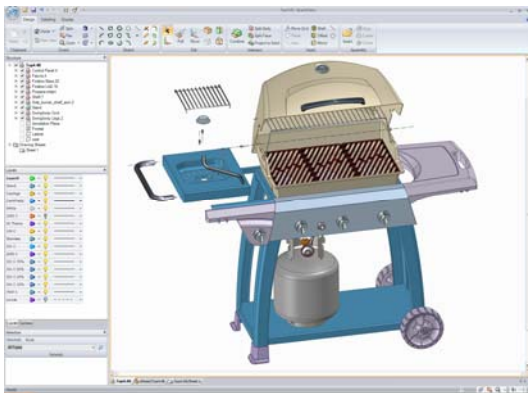

Assembly design capabilities include mate and alignment of parts within an assembly while maintaining the design flexibility to turn those associations on or off. Assembly associations are displayed within the assembly tree structure and can be activated or removed simply by selecting the corresponding check boxes.

TraceParts Library provides a library of over 100 million standard CAD models from leading parts manufacturers. The library is accessible from within SpaceClaim and the selected component is automatically created and inserted into the assembly.

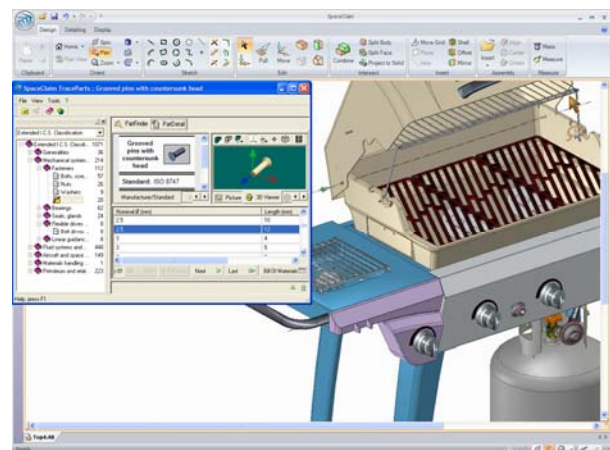

Combine provides a single tool for readily joining or splitting groups of geometry. Through the use of the combine tool, geometry can be split or merged within the part or across different parts. When there are multiple possible results, the geometry options are highlighted for the user to filter and select.

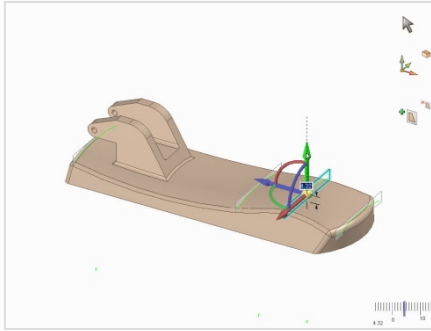

Edit as Blend provides the ultimate in design flexibility by enabling simple geometric shapes, such as a cylindrical surface, to be modified into a blended surface. The tool allows placement of 2D sections throughout the geometry and the ability to modify the 2D sections of any model, regardless of where it originated.

Mirror establishes a symmetrical association between like geometry in a part by selecting a plane that cuts through the part. The use of mirror lessens the time to create and modify symmetric parts, while maintaining design integrity. The mirror association can be turned on or off depending on the design needs.

Shell automatically removes material inside the part to a consistent wall thickness. The operation is ideal for designing plastic parts or castings. The tool automatically sets up an offset association between two paring surfaces that can easily be turned off or on, depending on the design needs.

Offset establishes an association between two surfaces so that they can be maintained as a thin wall during design modifications. Offset enables users to capture their current design intentions, yet retain the flexibility to change that association as their design evolves.

Fit in the Workflow

SpaceClaim Professional 2007 complements the use of 3D CAD in the product development process. SpaceClaim opens 3D models from another CAD system. Once the model is opened it becomes a native SpaceClaim model. Designs can be exchanged in a variety of native-CAD and industry standard formats. To document design changes, SpaceClaim includes a 3D mark-up capability. By maintaining a clear and precise representation of the 3D design throughout the development process, both design cycle times and downstream errors are reduced.

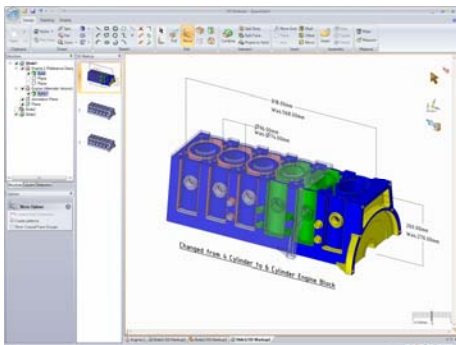

3D Mark-up is a documentation environment which includes a set of 3D annotation capabilities and highlighting tools to clearly communicate and document design changes. The environment includes mark-up dimensions, 3D annotations and comparison capabilities. 3D mark-up files can be attached to engineering change requests to clearly and unambiguously communicate the request.

“Was” Dimensions automatically show both the current dimensional value along with the original value prior to the design change as a 3D annotation on the model. This unique dimension capability removes the burden on the user to keep track of the changes and provides clear documentation of the modification.

Model Compare overlays the original model on the changed model and then automatically displays all differences in color-codes. These design differences can be communicated back to the design team using SpaceClaim Viewer or output to industry standard formats such as MS PowerPoint®, and XPS™.

2D Data Exchange includes support for DWG and DXF™ formats. 2D geometry imported from AutoCAD drawings can be used as the basis for a sketch to create 3D geometry. SpaceClaim allows you to preserve the value of your 2D data and easily convert it to 3D.

3D Data Exchange capabilities include both industry standard formats, included with SpaceClaim Professional 2007, and native CAD file formats. The complete list of supported formats and versions is as follows:

- **Data Import:** CATIA® V5 R6 – R17 SP1 and V4 4.1.9 – 4.2.4, NX® versions NX1 – NX4 and UG v11 – 18, Pro/ENGINEER® 16 - Wildfire 3, SolidWorks® version 98 - 2007, Inventor® 6-11, ACIS®, Parasolid® v10.0 – 18.0.141, IGES up to v5.3, STEP AP203, AP214 (geometry), VDA FS 1.0, 2.0 and JT Open.
- **Data Export:** CATIA V5 R17 SP1, ACIS, Parasolid v18.0, IGES v5.3, STEP AP203, AP214 (geometry), VDA FS 2.0 and JT Open.

Note: IGES, STEP, VDA, DWG and DXF data exchanges are included with SpaceClaim Professional 2007. Support for vendor-specific file formats, ACIS and Parasolid, and JT Open requires a separately purchased add-on product.

To learn more about SpaceClaim Professional 2007 please visit



www.ems-usa.com